

## PowerBar 600 Ampere Cable Connectors



### Specifications

|                     |   |
|---------------------|---|
| Continuous Amperage | 545 Amperes AC<br>600 Amperes DC            |
| Voltage Rating      | 300 Volts AC Maximum<br>48 Volts DC Maximum |
| Bus Material        | Tin-Plated Copper CDA 110/UNS11000          |
| Base Material       | Reinforced Polycarbonate                    |
| CE marked           |   |

| PN   | Description              | Weight Lb (Kg) |
|------|--------------------------|----------------|
| 2104 | 4 x 3/8-16 Stud Terminal | 1.71 (0.78)    |
| 2107 | 8 x 3/8-16 Stud Terminal | 3.42 (1.55)    |



2104



2107

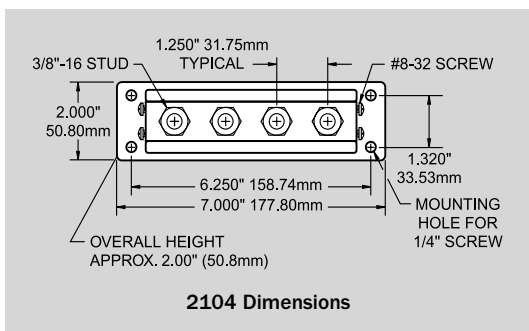

2104 Dimensions

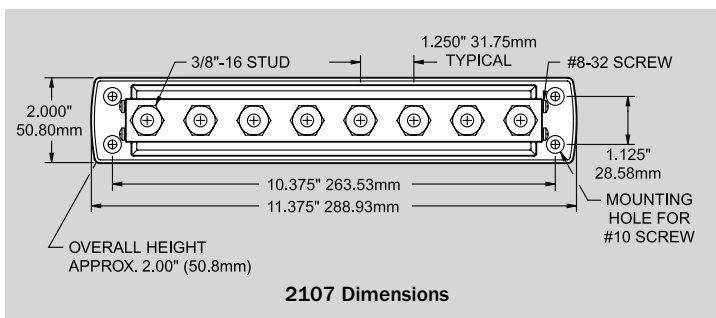

2107 Dimensions

## Cover For 600 Ampere Cable Connector

### Specifications

|                |     |
|----------------|-----|
| Cover Material | ABS |
|----------------|-----|

| PN   | Description       | Weight Lb (Kg) |
|------|-------------------|----------------|
| 2708 | Cover For PN 2104 | 0.09 (0.04)    |



2708



2104 with 1 AWG Cables